

# Analysis of Different Toolpath Strategies for Machining of The Steam Turbine'Blade on Surface Roughness and Machining Time

KHAIRUL JAUHARI , ENDARTO TRI WIBOWO, MAHFUDZ AL HUDA, ERWIEN YULIANSYAH, ACHMAD ZAKI RAHMAN, RUDIAS HAMADI, RICHARD HARRISON

<sup>1</sup>Research Organization for the Assessment and Application Technology (OR PPT), National Research and Innovation Agency (BRIN), PUSPIPTEK, Tangerang Selatan, INDONESIA.

**Abstract:** This paper presented investigation the effect of machining for different strategy on surface roughness and time consuming machining after the free form surface milling simulations based on machining the blade of steam turbine. The first stage of 5-axis milling simulations machining for steam turbine blades were performed using CAD (Catia) / CAM (Delcam) software. The accuracy of obtained allowance is defined as a difference between the theoretical surface of work piece element (the surface designed in CAD software) and the machined surface after a milling simulation. The difference between two surfaces describes a value of roughness, which is as the result of shape on the machined surface. An accuracy notifies a surface quality after the finish machining. The usage of these CAD/CAM software can reduce a time design of machining process for a steam turbine blades sculptured surfaces milling by a 5-axis CNC milling machine with allowed to perform the item on a milling machine in order to measure the machining accuracy for the selected strategies.

**Keywords:** Steam turbine blades, 3D photo-scanning, geometric accuracy, machining processes, sculptured surfaces.

Received: May 18, 2021. Revised: February 11, 2022. Accepted: March 9, 2022. Published: April 5, 2022.

## 1. Introduction

The various machining complex parts such as dies, molds and aerospace parts usually used five-axis milling processes [1]. This type of milling machine is mainly used for machining component such as steam turbine blades which the flexibility of thin-walled with sculptured surfaces [1–5]. It's consideribilities to using the 5-axis CNC are the machining surface roughness for dimensional quality and time machining of parts due to select the correct trajectories of cutting tools for instance, avoid collision between a tool and work piece material or re-machining of part element which has been correctly machined [6-9]. The effect of proper machining tooling strategies and cutting data (such as spindle speed, depth of cut, step-over,

etc) are mostly based on a measurement of previous machined elements, the database for the particular materials or a knowledge of an operator [10-15]. Designing of free form sculptured surfaces machining without to use CAM software is very difficult and more times consuming. DELCAM software is used to design a milling process of element with free form surfaces on 5-axis CNC machines without to check a machining accuracy. The used of CAD/CAM software (Computer Aided Design/Computer Aided Manufacturing) in the design of machining elements with free form sculptured surfaces can performing the entire technology cycle from a construction to a machining simulation (from 3D model to

simulation of machining process)[16-19]. The stage of technology can allowed to simulate different machining tool strategies and to select the most optimal at all. The choice of technology methods are based on the optimisation criterion, for example, the smallest time of machining, minimum volume of machining allowance, largest dimensionally-shaped accuracy, and etc [16,20]. The Application used of CAD/CAM software can reduce time consuming of design machining process for the workpiece element, indicating the collision place and inappropriate cutting data and etc. The final result for using the application of CAM software is to demand a conduct NC program for the specific CNC machine by a required postprocessor. In practise, firstly, the NC program is performed in the CAM software; afterwards the element (prototype) is made on a CNC machine. The last stage is a verification of work-piece accuracy. Inappropriate selection of machining strategies, cutting data as well as cutting tools causes to obtain the element which incorrect dimensionality-shaped precision. Re-machined of the element is associated with additional costs and loss of time for manufacturer. In the CAM environment, it is only perform the simulation of milling process without to control a machining accuracy after the milling simulation.

In this paper the machining process of steam turbine blades on a CNC machine, verification of particular milling strategies and cutting data are time consuming that contributed to the idea for checking the machining accuracy of the milling element (with free form surfaces)

in CAM environment. The 3D model of a steam turbine blade is analyzed after a milling simulation for the chosen milling strategies at the suitable cutting data and cutting tools, respectively. The values of machining accuracy are determined after simulation as the difference between carried out the surface after milling simulation in CAM environment and the theoretical surface designed in CAD software (surface designed by the constructor). Value of un-machined material after simulation identifies the designed machining precision for the selection strategy, cutting data, type of cutting tools as well as machine kinematics, respectively.

## 2. Methodology

In order to enable improve design of machining process for turbine blade sculptured surfaces was proposed the method carries through analysis of the machining accuracy calculation depend on the radial depth of cut  $ae$ . Accuracy of the radial depth of cut is carried out by a computer simulation and describes a height of roughness after milling simulation as an effect of the tool shape mapping on a work piece surface. This method is described according to own algorithm (Fig. 1). The first step of proposed algorithm allows defining the input data which are following:

Established maximal height of roughness, which would be obtained as a result of the tool shape mapping on the workpiece; the used tools for diameter and shape; the shape of work piece surface. For the next stage, in CAM software is

generated tool paths for the selected strategy and calculates a radial depth of cut. After this stage is performed the milling simulation, which allows to obtain a geometrical model of the work piece surface. The next stage is a calculation of obtained height roughness. The roughness describes a tool shape mapping on the machined surface. Value of height roughness is defined as a difference between the nominal surface and the surface obtained during the milling simulation. Thanks to the calculated height of roughness and their positions on the machined surface is possible to check for all the analysed surface is satisfied the request condition (the roughness  $R$  obtained as the result of tool shape mapping is lower or equal than established values of  $R_{max}$  declared during the first step of the algorithm). In case of situation, when the condition is fulfilled, a NC-code could be generated and then will be machined on a CNC machine. If the condition is not satisfaction, that need to generate new tool paths with a new values of the radial

depth of cut or/and another tool or/and another milling strategy.

### 3. Results and Discussions

In this study, the effect of machining for different strategy on surface roughness and time consuming machining were obtained. Analyzes of the machining simulation using CAM POWERMILL 2014 software was performed by considering several machining strategy models such as surface finishing, rotary finishing, raster finishing, optimized constant Z finishing and 3D offset finishing. In order to illustrate how the different strategy machining technique can be used to obtain the best surface roughness and time consuming of the steam turbine blade, a computer analysis manufacture simulation of example was done. A schematic of the 3D element model of the steam turbine blade system is shown in Fig. 2, and the workpiece clamping model is also shown in Fig. 3.

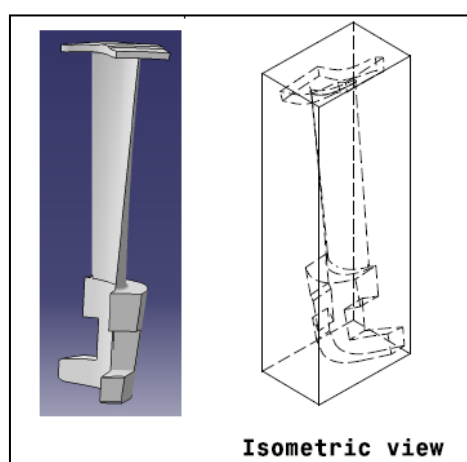

Figure 2. Steam turbine blade system turbine blade system

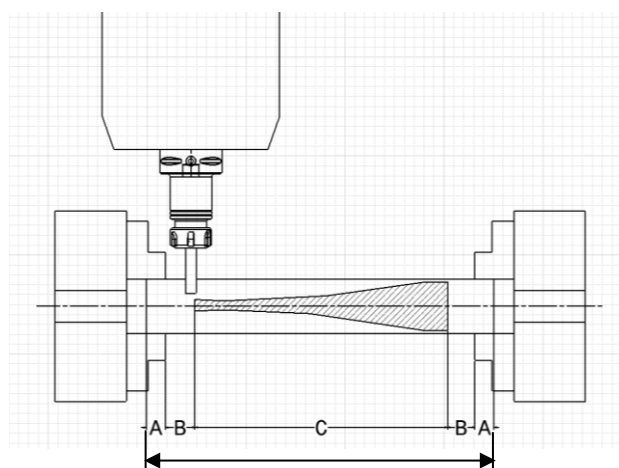

Figure 3. Clamping model of the steam turbine blade system

### 5.1.1. Raster Finishing

The first, a machining strategy model with surface finishing, this is a finishing strategy tool which using one surface selected for feeding. As can be seen from Fig. 4 that the cutter movement on the surface finish, the cutter can move according to the shape of the surface so that it is possible to produce a complex surface shape with good surface roughness. From the simulation results, the roughness level is 2 mm and the processing time is about 3 hours. The second, a machining strategy model with rotary finishing, this is a finishing strategy tool by using an axis to rotate its motion similar to turning so that it can work on asymmetrical surface shapes. As can be seen from Fig. 5, in the rotary finishing strategy, the cutter direction is always perpendicular to the direction of the rotating axis, this movement can be done on a simultaneous 4 axis CNC machine. From the simulation results, the roughness level is 2 mm and the processing time is about 3 hours. The third, a machining strategy model with raster finishing. As can be

seen from Fig. 6, raster finishing is a finishing tool strategy that is similar to raster movement in roughing or semi-finish, but with the use of smaller tools, step over and depth of cut which can be adjusted to obtain smoothness and precision. From the simulation results, the roughness level is 2 mm and the processing time is about 8 hours. The fourth, a machining strategy model with optimized constant Z finishing. As can be seen from Fig. 7, Optimized Constant Z finishing which is a strategy tool finishing with a constant depth of cut automatically while setting the step over distance with the infeed direction adjusting the shape of the object. From the simulation results, the roughness level is 2 mm and the processing time is about 9 hours. The last, 3D Offset Finishing is a finishing strategy tool with the direction of feed movement extending to the shape of the object according to the horizontal object surface as shown in Fig. 8. From the simulation results, the roughness level is 2 mm and the processing time is about 7 hours.

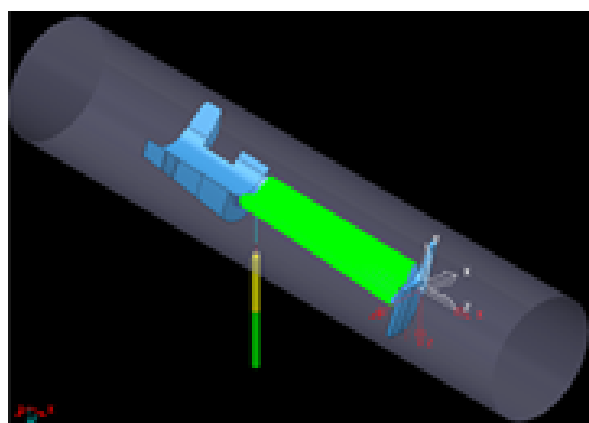
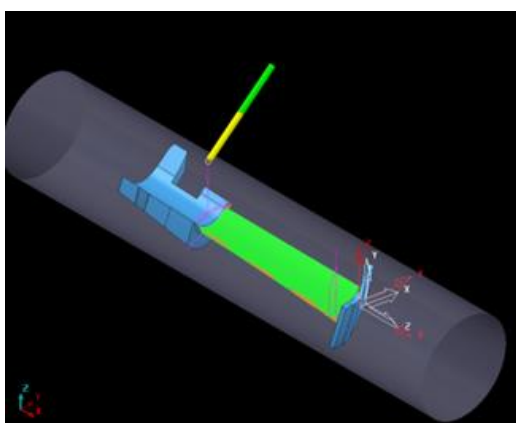

Figure 4. Surface finishing

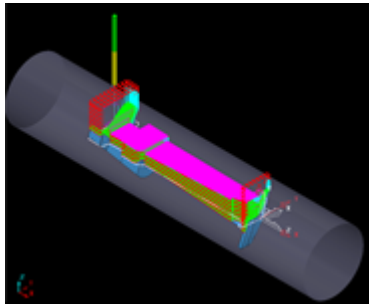

Figure 5. Rotary finishing

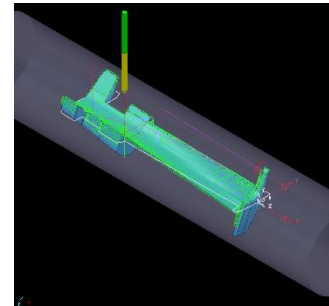
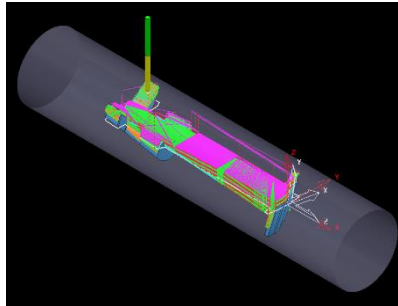

Figure 6. Raster finishing

Figure 7. Optimized constant Z finish Figure 8. 3D Offset Finishing

### 3.2 Machining Time

From the comparison between the five finishing strategy tool paths, it can be seen that for the finishing process on the blade, the longest processing time is at optimized constant Z finishing with a time of 9 hours 38 minutes or about 30% of the total finishing time, while the fastest finishing time on surface finishing and rotary finishing strategies with the same time is 3 hours 11 minutes or about 10% ss can be seen from Fig. 9. Thus, if the machining process as a whole from the beginning of roughing to finishing with the finishing process selected at Optimizide constant Z finishing, it will be seen that the comparison of processing time will require a total time of 84 hours 44 minutes,

whereas the finishing process with Optimizide constant Z takes 11% of the whole process (Fig. 10). Then if in the machining process for the finishing process a tool strategy with surface finishing is used, then for the overall process from the beginning of roughing to finishing it will be seen that the comparison of the total processing time will be 78 hours 17 minutes (Fig. 11). It can be seen by using a finishing strategy tool with surface finishing where the time is the fastest so that it can affect the total work time compared to choosing a finishing strategy tool with optimized constant Z. So using surface finishing will save 6 hours 27 minutes compared to working time with optimized constant Z finishing.

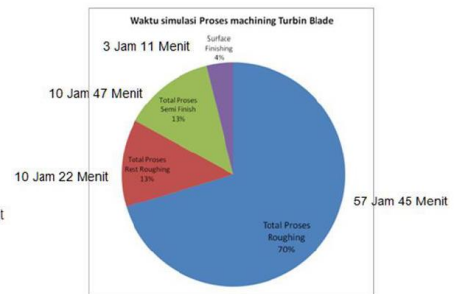
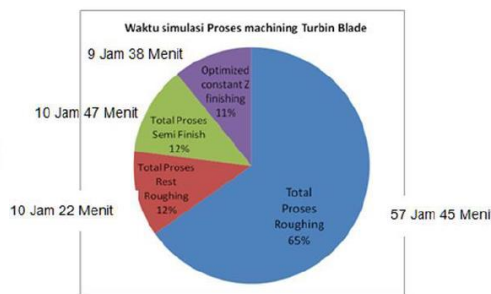
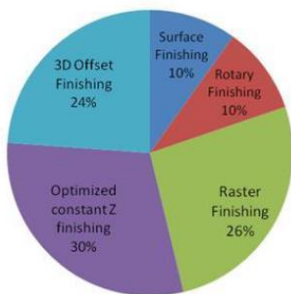

Figure 9. Time of finishing strategy.

Figure 10. Time of Optimized Constant Z.

Figure 11.

Time of Surface Finishing

### 3.3 Effect of Toolpath Strategies on Surface Roughness

The difference in the direction of feeding will greatly affect the smoothness of the surface of a product. Meanwhile, especially in the turbine blade surface smoothness is very important to improve the performance of the turbine rotor performance. For this reason, in the consideration of the tool strategy selection when finishing, it is not only seen from the time required, it is also necessary to consider the direction of the feeding flow and the smoothness of the results

It was found that Optimized Constant Z finishing, which is a strategy tool finishing with a constant infeed depth, is automatically set at a step over distance with the feed direction adjusting the shape of the object. In this strategy tool the direction of movement is formed automatically, so it is difficult to adjust the direction of movement to follow the desired design direction. From the flow of the movement it looks less regular in the direction of the groove so that there is a lot of movement (link) so that because of that the feeding time becomes longer and the surface results will be less smooth. However, in surface finishing movement the cutter can move to follow the shape of the surface, thus enabling complex surface shapes with multi-axis tool movements. There is a tool movement that follows the shape of the surface and the cutting angle that can be adjusted so that the surface of the object can be smoother, and with this movement it will be efficient in feeding because the movement of moving positions

(links) is very little.

## 4. Conclusions

A computer analysis manufacture simulation CAM POWERMILL 2014 software was performed by considering several machining strategy models such as surface finishing, rotary finishing, raster finishing, optimized constant Z finishing and 3D offset finishing has been implemented to obtain optimum good roughness and time consuming results. The simulation results are validated with five real machining tool strategy experiments Based on the results of the comparison of the five machining strategy models, it is found that the best surface roughness occurs in the surface machining model with the minimum profile height compared to other models, which is surface roughness finishing and the resulting machining process is also the fastest when compared to other models, which is approximately 3 hours.

### Conflicts of Interest

The authors declare no conflict of interest.

### Acknowledgements

This paper was funded by an incentive research grant from Ministry of Research, Technology and Higher Education of the Republic Indonesia, which the authors gratefully acknowledge. All authors contributed equally to this work. All authors discussed the results and implication and commented on the manuscript at all stages.

*References*

- [1] Young, H. -T., Chuang, K., Gerschler, K., "A five-axis rough machining approach for a centrifugal impeller," *Int J Adv Manuf Technol* 23, 233-239 (2004).
- [2] Chih-Hsing, Ch., Way-Nen, H., Yu-Wei, L., "An integrated framework of tool path planning in 5-axis machining of centrifugal impeller with split blades," *J Intell Manuf* 23, 687-698 (2012).
- [3] Senatore, J., Monies, F., Rubio, W., [Machining of Complex Sculptured Surfaces], Springer-Verlag, London, 33-66 (2012).
- [4] Zębala, W., "Modelling of multi-layer materials cutting," *Adv in Manuf Sci and Tech* 36(1), 9-18 (2012).
- [5] Monaro, R. L. G., Helleno, A. L., Schutzer, K., "Evaluation of Dynamic Behavior of Machine Tools for Sculptured Surface Manufacturing," *Proc. CIRP* 7, 317-322 (2013).
- [6] Quinsta, Y., Lavernhe, S., Lartigue, C., "Characterization of 3D surface topography in 5-axis millin," *Wear* 271, 590-595 (2011).
- [7] Olvera, D., Calleja, A., Lopez de Lacalle, L. N., Campa, F., Lamikiz, A., [Machining of Complex Sculptured Surfaces], Springer-Verlag, London, 1-33 (2012).
- [8] Zębala, W., "Tool stiffness influence on the chosen physical parameters of the milling process." *Bull Pol Acad Sci-Te* 60(3), 597-604 (2012).
- [9] Rauch, M., Hascoet, J., [Machining of Complex Sculptured Surfaces], Springer-Verlag, London, 127-156 (2012).
- [10] Boz, Y., Khavidaki, S. E., Erdim, H., Lazoglu, I., [Machining of Complex Sculptured Surfaces], Springer-Verlag, London, 67-126 (2012).
- [11] Ozturk, E., Tunc, L. T., Budak, E., "Investigation of lead and tilt angle effects in 5-axis ball-end milling processes," *Int J Mach Tool Manu* 49, 1053-1062 (2009).
- [12] Lopez de Lacalle, L. N., Lamikiz, A., Sanchez, J. A., Salgado, M. A., "Toolpath selection based on the minimum deflection cutting forces in the programming of complex surfaces milling," *Int J Mach Tool Manu* 47, 388-400 (2007).
- [13] Fontaine, M., Moufki, A., Devillez, A., Dudzinski, D., "Modelling of cutting forces in ball-end milling with tool-surface inclination Part I: Predictive force model and experimental validation," *J Mater Process Tech* 189, 73-84 (2007).
- [14] Zębala, W., "Modelling researches of the vibrations influence on the cutting process," *Adv in Manuf Sci and Tech* 29, 99-107 (2005).
- [15] Ozturk, E., Tunc, L. T., Budak, E., "Investigation of lead and tilt angle effects in 5-axis ball-end milling processes," *Int J Mach Tool Manu* 49, 1053-1062 (2009).
- [16] Krimpenis, A., Fousekis, A., Vosniakos, G., "Assessment of sculptured surface milling strategies using design of experiments," *Int J Adv Manuf Technol* 25, 444-453 (2005).
- [17] Zębala, W., Matras, A., [Development in Machining Technology. Scientific Research Reports 3], Wydawnictwo Politechniki Krakowskiej, Kraków, 7-19 (2013).
- [18] Dotecheva, M., Dotech, K., Popov, I., "Modelling and Optimisation of Up-and Down-Milling Processes for a Representative Pocket Feature," *Int J Precis Eng Man* 14(5), 703-708 (2013).
- [19] Geng, L., Zhang, Y. F., [Machining of Complex Sculptured Surfaces], Springer-Verlag, London, 191-228 (2012).
- [20] Zębala, W., Słodki, B., Struzikiewicz, G., "Productivity and reliability improvement in turning Inconel 718 alloy – case study. Poprawa produktywności i niezawodności toczenia stopu Inconel 718 – stadium przypadku." *Ekspluat Niezawodn* 15(4), 421-426 (2013).