

# Reducing energy consumption when charging electric vehicle batteries using ferroelectrics

V. I. ZUBTSOV

Department of Construction Industry  
Polotsk State University  
Novopolotsk, BELARUS

*Abstract* : Segnelectric energy is used as a charger or charging stations. By controlling the polarization of the ferroelectrics, additional electrical energy is generated, 2.5...4 times higher than the energy consumed from an alternating electrical voltage source.

*Keywords*: Electric car, energy, electric power, ferroelectrics, polarization, batteries

Received: April 4, 2022. Revised: October 9, 2022. Accepted: November 5, 2022. Published: December 2, 2022.

## 1. Introduction

One solution to existing environmental problems is the production of electric vehicles. The mass transition to electric vehicles will require a significant increase in the amount of electricity produced and the creation of networks of chargers and charging stations.

To solve this problem, an energy unit (EU) was developed, which is a charger and charging station for slow, fast and accelerated charging of batteries using the polarization control of ferroelectric.

Briefly, the principle of the EU operation is to release the "frozen" energy of the chemical reaction between the oxidizer and the substance of the ferropiezoactive, which is a multicomponent system of solid solutions [1].

Polarization control boils down to the technology of energy reduction by changing the compressibility and electroelasticity of multicomponent ferropiezoactive dielectrics [1, 2]. As a result, additional energy is released, which is 3.5- 4 times greater (depending on the electrical modification of the ferroelectric and incorporation into electric circuits) than the energy consumed from an alternating voltage source. It is formed in two stages: the first stage is the increase in polarization of the segmentelectric, and the second stage is the increase in electric power at the EU output [3]. Structurally, an EU is a multicomponent piezoceramic element of a certain size and shape with metal contacts and current leads attached to them for inclusion in an electrical circuit. A ferroelectric is a multicomponent

ferropiezoelectric element with important characteristics for electromechanical transducers, high piezo- and dielectric properties: mechanical strength and electroelasticity. It also meets certain requirements: seriality, compactness, adaptability, etc. [4]. Therefore, EU is easy to implement. In addition, this ceramic is relatively inexpensive to produce. In connection with the above, the use of ferroelectric ceramics EU as a charger or charging station allows you to do with less of them, saves electricity by about 3.5 - 4 times and, of course, the cost of charging.

## 2. Description of the principle of operation and design of the EU. Mathematical model of electromechanical converter combined with electrochemical generator

In connection with the above, an alternative innovative technology using an electrochemical generator (ECG) based on ferro-piezoelectric ceramics was developed EC. Such an ECG simultaneously increases the specific power and specific energy. Theoretical and experimental studies show that ferro-piezoelectric ceramic-based devices, for which artificially produced ferro-piezoelectric ceramics are used, may be a more effective alternative to the devices and technologies currently used by leading companies [1- 4].

Currently there are opportunities to obtain significant electrical currents (bias currents) in dielectrics due to the improved electrical

characteristics of ferro-piezoelectric ceramics and physical-and-technical solutions (technologies) [3, 5].

A 3.5-4-fold increase in energy is achieved by modifying the ferro-piezoelectric ceramics, electrical circuit, mechanical loading conditions, second-order ferroelectric transition, interlayer and dipole polarization [3-5, 6]. The EU consists of a control unit (electromechanical converter and a simple easy to implement device for generating mechanical energy), ECG and a matching device, figure 1. The EU increases energy from a source of alternating electric voltage in two stages: the first stage is to increase the degree of polarization of ECG, the second is to increase the electrical power at the output of the power plant, that is, the load, figure 4. Briefly, the principle of operation of ECG, which is the main unit of the unit for increasing energy, is to release the "frozen" energy of the chemical reaction of the oxidant and ferro-piezoelectric ceramic element, which is a multicomponent system of solid solution. Structurally, ECG is a ferro-piezoelectric ceramic element of a certain size and shape with metal contacts and attached leads for its connection to the electric circuit

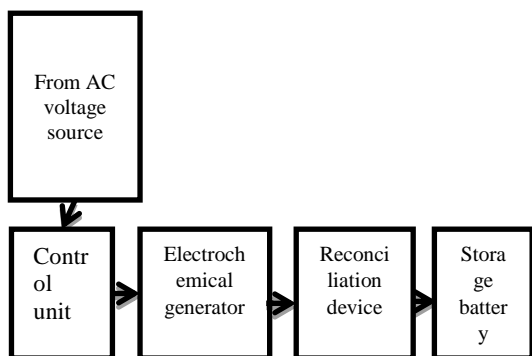

Fig. 1. Functional diagram of the EU.

An increase in the degree of polarization of ferro-piezoelectric ceramic elements is achieved by controlling their compressibility and energy elasticity [1, 5]. The constructions of the electromechanical transducer and ECG, in addition to ferro-piezo electric elements, which can be represented as a resonant circuit, have other secondary elements. Therefore, in dynamics, these spring-mass structures have a complex spectrum of their own frequencies and in an electric circuit represent a series-parallel circuit [1, 6], which has two frequency constants: two resonances – a series one with frequency  $f_r$  and a parallel one (the so-called antiresonance) with frequency  $f_a$ .

For ECG efficient use, it is important to determine the range of its operating oscillation frequencies. Let us consider a simplified mathematical model of an electromechanical transducer in interaction with ECG. Suppose that a ferroelectric ceramic plate serves as an electromechanical transducer and produces compression oscillations along its length, figure 2. To create a mathematical model it is necessary to work out the equation of motion of the transducer, select the ferro-piezoelectric effect equations, and also make basic assumptions. The main assumptions are as follows:

- all mechanical stresses, except for stresses in the direction of the transducer, are zero;
- the amplitude of alternating mechanical stresses and strains is not more than the maximum limiting values;
- the change of the reactive component of the transducer impedance at the operating frequencies has capacitive effect.

Let us determine the frequency constants of the transducer by solving the differential equations of the piezoelectric oscillations for the assumptions defined above.

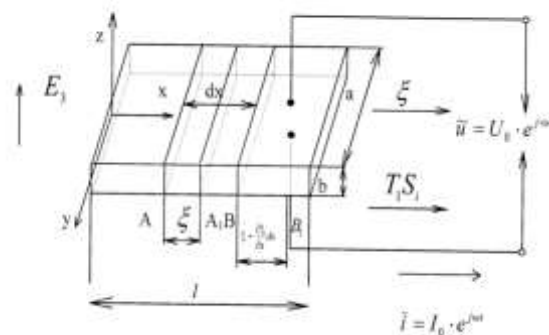

Fig. 2. Diagram of the electromechanical transducer in interaction with ECG.

The equation of motion of the transducer is:

$$\frac{\partial^2 \cdot \xi}{\partial \cdot x} = \frac{1}{v^2} \cdot \frac{\partial^2 \cdot \xi}{\partial \cdot t^2}, \tag{1}$$

where  $\xi$  is amplitude of oscillation (displacement);

$v = \sqrt{\gamma/\rho}$  - speed of elastic wave propagation in the plate;

$\gamma$  - modulus of elasticity of ferro-piezoelectric ceramics;

$\rho$  - ferro-piezoelectric ceramics density;

l, a and b - length, width and thickness of the plate, respectively;

t- time.

This is a well-studied partial differential equation of second order.

The equation of motion of the transducer is solved by variable separation method:

$$\xi(x, t) = \mathbf{X}(x) \cdot \mathbf{T}(t),$$

$$\frac{1}{\mathbf{X}(x)} \cdot \frac{\partial^2 \mathbf{X}}{\partial x^2} = \frac{1}{v^2} \cdot \frac{1}{\mathbf{T}(t)} \cdot \frac{\partial^2 \mathbf{T}}{\partial t^2} = -n^2$$
(2)

The solutions are the following, respectively:

$$X = A \cdot \cos nx + B \cdot \sin nx,$$

$$T = C \cdot \cos nvt + D \sin nvt$$

$$= M \cdot \cos(nvt + \varphi),$$

wheren = m · π/1 (m = 1,2,3 ...).

(3)

The resonance and antiresonance oscillation frequencies of the ferro-piezoelectric plate are determined for a fixed transducer. The boundary conditions are written as follows:

$$\xi(x, t) = X(0) \cdot T(t) = 0,$$

$$\xi(x, t) = X(l) \cdot T(t) = 0,$$
(4)

where l is length of the plate. Omitting the intermediate calculations shown in [1, 4], we present the unknown expressions for  $f_r$  and  $f_a$ .

$$f_r = \frac{1}{4l} \cdot \sqrt{\frac{Y_{11}}{\rho}} \text{ kHz}, f_a = f_r \left( \frac{K_c^2}{2.46} + 1 \right) =$$

$$\frac{1}{4l} \left( \frac{K_c^2}{2.46} + 1 \right) \cdot \sqrt{Y_{11}/\rho}, \text{ kHz}$$
(5)

Thus, it is possible to determine approximately the resonance and antiresonance frequencies, which is important for calculating the technical specifications for the power plant.

If an alternating electric voltage is applied to a segmented dielectric, the polarization does not follow the electric field, resulting in dielectric loss. When a mechanical load is applied, the deformation is established with a delay. That is, these processes correspond to a phase shift. All materials in varying degrees are subject to relaxation processes. Relaxation processes in ferroelectrics are manifested due to mechanical and dielectric losses. A peculiar feature of ferro-

piezoelectric ceramics, operating in dynamic mode, is the presence of both types of losses. At low frequencies, the angles of dielectric and mechanical losses in it make a total loss angle  $\delta$ , defined through  $K_c$  [1, 7], see equation (6). Therefore, the polarization is considered as a complex number:  $\varepsilon_{rk} = \varepsilon_r - j \varepsilon_r'$ , where  $\varepsilon_r$  is relative dielectric constant;  $\varepsilon_r'$  - imaginary part of the complex number, loss coefficient ( $\varepsilon_r' = \text{tg} \delta \cdot \varepsilon_r$ );  $\text{tg} \delta$  - loss characteristic;  $\delta$  - phase shift angle.

The frequency characteristics  $\varepsilon_r$ ,  $\varepsilon_r'$  and  $\delta$  depending on the normalized frequency  $\omega/\omega_0$  are as shown in figure 3.

Now it is possible to explain ECG operation principle in more detail. Under mechanical load, as a result of the clamping of ferroelectric, there is a sharp decrease in  $\varepsilon_r$ , figure 3, which leads to electrical capacity reduction and an increase in  $K_c$ , that is, to a sharp increase in the efficiency of conversion of mechanical energy into electrical energy. In a certain frequency range between the resonance and the antiresonance, where the deformation will increase sharply to a greater extent than is due to mechanical load, a sudden absorption of mechanical energy occurs. This leads to a sharp increase in the degree of polarization.

Reducing the electrical capacitance of the ferroelectric ECG leads to an increase in the electrical voltage  $U_0$ , see equation (7), and, therefore, an increase in the electrical power in the load EU. Phase transitions in ferroelectrics occur within certain temperature ranges. In this connection, it should be noted that in ferroelectrics some piezoelectric moduli, characterizing the change in the degree of polarization under mechanical loading, reach very large values during phase transitions, theoretically passing into infinity. Thus, the effect of mechanical load in a certain frequency range and the effect of thermal energy in a certain temperature range are a sort of a catalyst of chemical reactions in solid solutions of ferroelectrics.

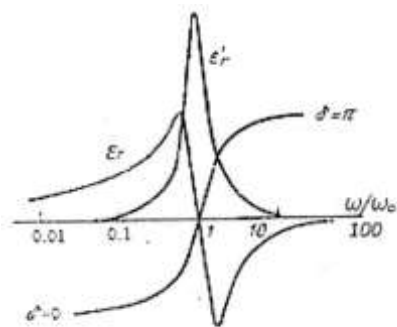

Fig. 3. To the analysis of ECG resonance parameters.

The absolute dielectric constants,  $\epsilon_{\alpha}^S$  of the clamped element in this case are, of course, less than  $\epsilon_{\alpha}^T$  of the free one and are linked by equation of electromechanical coupling:

$$\epsilon_a^S = \epsilon_a^T \left( 1 - \frac{d^2}{S^E \epsilon_a^T} \right) = \epsilon_a^T (1 - K_c^2) \tag{6}$$

where  $K_c$  is electromechanical coupling coefficient,  $S^E$  is elastic compliance while the electric field strength is  $E=0$ ,  $\epsilon_{\alpha}^T$  is absolute dielectric constants where the mechanical stress is  $T=0$  and  $d$  is piezoelectric module [4,5].

In the general case, the transformation function (ECG) is of the form:

$$U_0 = K_u \frac{d_{ij} \cdot F}{C_{ECG} + C_L}, \tag{7}$$

where  $U_0$  means output electric voltage of ECG,  $F$  is acting mechanical force,  $C_{ECG}$  is electrical capacity of ECG,  $C_L$  is electrical load capacity (load electrical devices),  $K_u$  is coefficient of electric voltage increase due to the increased degree of polarization of ferroelectric and  $d_{ij}$  is piezoelectric module, induced polarization per unit of mechanical stress.

From equation (6) it is obvious that the value of  $K_c$  has a significant effect on the ratio of dielectric constant of clamped and free ferroelectrics, i. e. change in the dielectric constant under the action of mechanical load. For example, in case of  $K_c = 0.5$  (an averaged value), this ratio will be 0.75. Which, in its turn, is highly important (especially since in modern ferro-piezoelectric ceramics  $K_c = 0.6 \dots 0.7$  for output electric voltage (output power) of the power plant, see equation (7), as dielectric constant and electrical capacity are directly proportional.

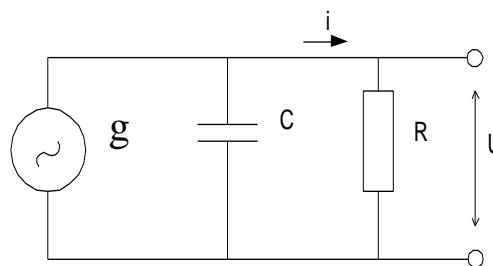

Fig. 4. Simplified equivalent diagram of the ESP, reflecting its capacitive nature of electrical resistance.

- g - electric charge generated by the piezo effect;
- C - capacitance of the ECG;
- R - internal resistance of the battery, power plant load;
- U - output electric resistance of the power plant.

Fig. 5 shows the character of the electrical voltage change for ECG at frequencies below resonance, where the oscillator resistance can be considered purely capacitive.

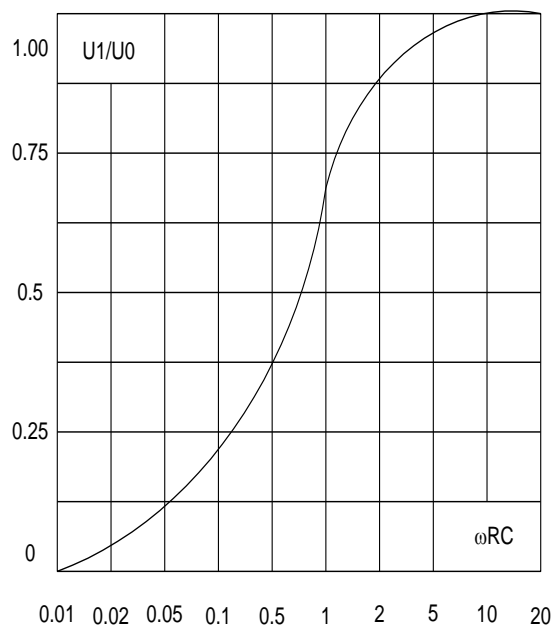

Fig. 5. Frequency response of ECG.

$U_0$  - this is the amplitude value of the voltage that appeared on the capacitance  $C$  at  $R \rightarrow \infty$ .

$U_1$  - voltage proportional to the change in mechanical load  $F$ , (7).

The curve in Fig. 5 is a part of the experimental amplitude-frequency response of the electromechanical transducer made of the ferroelectric material PZT-19, diameter 10x1 mm with a mechanical load of 2.5 MPa (see in [2], Fig. 4. 1, curve 2), in the frequency range between antiresonance and resonance.

Within the elasticity limits of the ferroelectric material, the electrical resistance of the ESG at a frequency below resonance can be considered purely capacitive, Fig. 4. And electric capacitance is charged by voltage (unlike inductance, which is "filled" by the magnetic field under the action of current). Therefore, the output power of the EC is transferred to the load at high voltage, which allows the use of smaller and lighter connecting cables.

For the coordinated operation of the ECG and the battery, capacitance and inductance are added to the circuit, as well as a rectifier, in parallel and in series with the load. The capacitance and inductance are necessary to match the high output resistance of the ECG and the low resistance of the battery, and the rectifier is necessary to obtain a constant voltage during charging.

The technology has no analogues. The main components of the EU are protected by copyright certificates and patents [1], and the performance has been tested in experimental studies.

### 3. Conclusion

The proposed alternative innovative technology has an advantage over solar and wind energy: it does not depend on climatic conditions and time of day, has a higher efficiency and is cheaper to produce.

Controlling the degree of polarization of ferroelectrics to increase energy is mainly determined by the following:

- Ferroelectric modification and electrical connection scheme;
- mechanical load (design features of the power plant);

- interlayer or dipole polarization of ferroelectrics in the frequency range of about 1...1.5 (103 - 105) Hz.

### References:

- [1] Zubtsov V. I. Control of the physical properties of materials using piezoelectrics Saarbrücken: LAP LAMPERT (Academic Publishing), 2013 - 262 p.
- [2] Zubtsov V.I., Zubtsova E.V. Segnetoelectrics in improving the efficiency of electric vehicles/ (Europe an Union: LAP LAMBERT Academic Publishing), 2021 - 54 p.
- [3] Zubtsov V. I., Zubtsova E.V. Improving the efficiency of electric transport drives by controlling the polarization of segmentelectrics // International Journal of Circuits and Electronics.- 2021. No. 6.- p. 55-59.
- [4] Zubtsov V. I., Bosylev V. V. and Zubtsova E. V. Design and tests of piezotransducers for control of stress in deformable medium Devices and Systems. Management, Control, Diagnostics. – 2011- No. - 2.- p. 45-50.
- [5] Zubtsov V. I. Efficiency of ferroelectrics application in technologies of simultaneous increase of specific capacity and electric drive power of light electric vehicles and alternative energy devices International science project. 2017 – No.7. – p. 15-20.
- [6] Zubtsov V. I. Increase in the range of measurements of static mechanical stresses in controlled environments Instruments and Systems. Management, Control, Diagnostics. 2003- No. 11.-p. 32-35.
- [7] Okazaki K. Manual on Electrical Materials (Moscow: Mechanical Engineering), 1979, - p. 432.
- [8] Zubtsov V. I. Nondestructive evaluation of elastic materials' durability Devices and Systems. Management, Control, Diagnostics, 2005- No.- 1 .p. 28-32.
- [9] Zubtsov V. I., Baranov V.V. and Emelyanov V.I. Piezocrystal transformers for measuring static mechanical stresses in Situ Proceedings of SPIE International Symp.Cannes (France), 2002 – p. 815-820.

